

SERITAB 2500 x 1000 MANUAL SILK-SCREEN PRINTING MACHINE

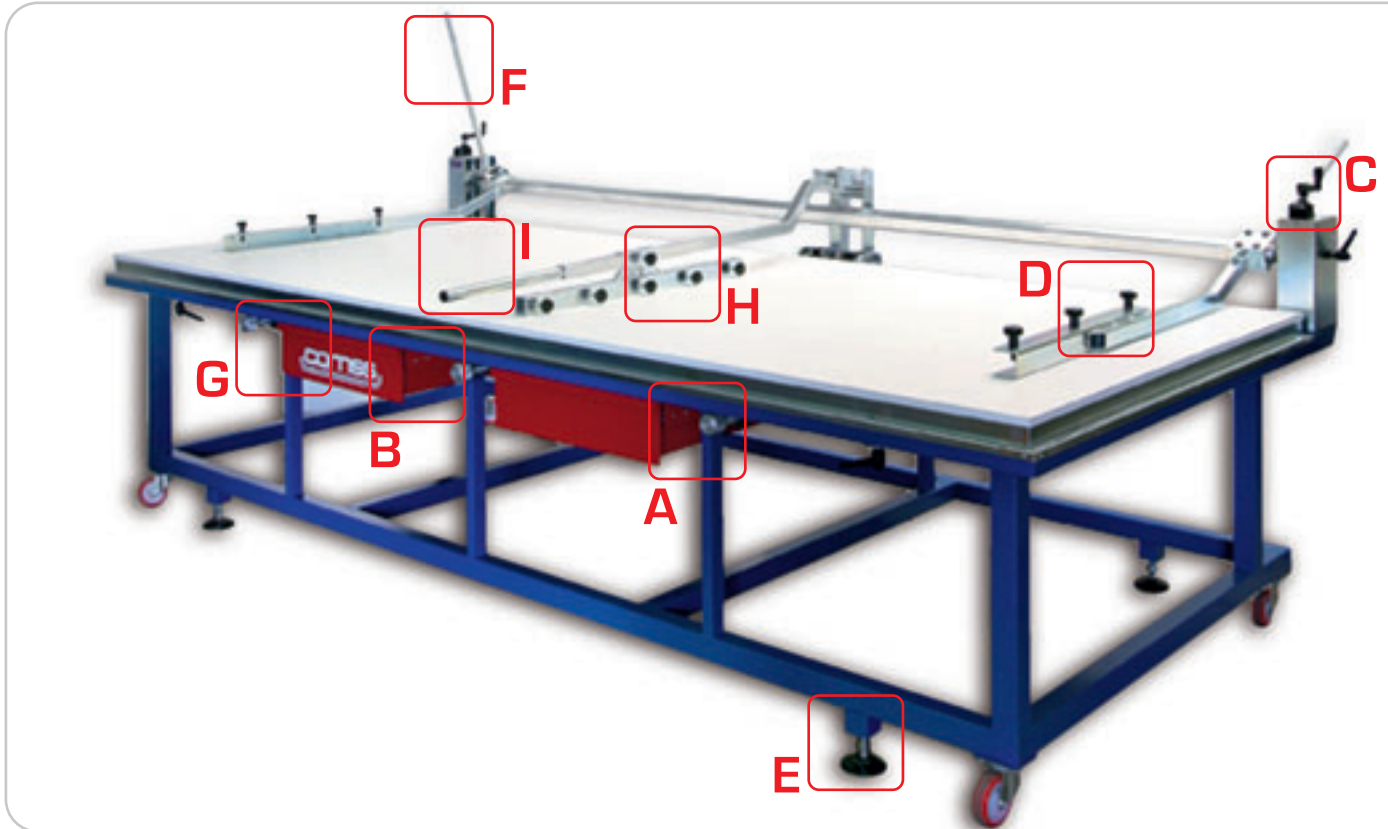

TECHNICAL CHARACTERISTICS

TECHNICAL DATA

| | | |
|------------------------------|----|----------------------|
| Max printing size dimensions | mm | 2500 x 1000 |
| Max printing Thickness | mm | 40 |
| Max frame dimensions | mm | 3100 x 1400 |
| Machine body dimensions | mm | 3600 x 1500 x h 1300 |
| Working table dimensions | mm | 3550 x 1250 |
| Working table height | mm | 860/900 |

DETAIL DESCRIPTION

| | | |
|----------------------------------|-------------------------|-------|
| A - Y-axis adjustment handwheel | Range | mm 40 |
| B - X-axis adjustment handwheel | Range | mm 40 |
| C - Height adjustment handle | Range | mm 50 |
| D - Frame support clamp | Minimum frame thickness | mm 20 |
| | Maximum frame thickness | mm 50 |
| E - Adjustable articulated feet | | |
| F - Counterweight bar | | |
| G - Tool drawers | | |
| H - Squeegee holder clamp | | |
| I - Servo-assisted printing unit | | |

SERITAB 2500 x 1000 MANUAL SILK-SCREEN PRINTING MACHINE

STRUCTURE

The load-bearing structure is made of steel tubes and is equipped with pivoting wheels for easier transportation and adjustable articulated feet for levelling the table.

PRINT BED

It consists in a layer of wooden material with laminated surface and non-scratch finish. The printing bed is equipped with micrometric regulations along the X and Y axes to facilitate the setting and centring of the silk-screen frame with the panel to be printed. The micrometric regulations are carried out by means of purposely designed knobs located on the front of the machine [A - B]. The print bed is also equipped with a lever locking system used to maintain the position obtained at set-up. The locking levers are located near the knobs of axis Y. The release levers must be loosened during set-up phase.

FRAME HOLDER CLAMPS

The silk-screen frame is mounted on purposely designed clamps that can slide along the support shaft to match the dimensions of the silk-screen frame to use. The frame is locked in position by means of screw knobs. The two columns that support the shaft are equipped with vertical regulation [C] to match the thickness of the panel to be printed. The folding aperture is assisted by counterweights that also ensure the positioning (high - down).

PRINTING UNIT (optional)

It consists of a carriage [I] that slides on the guides fitted on the machine structure. The carriage supports an articulated arm complete with squeegee-holder clamp [H]. The length of the squeegee is selected according to the dimensions of the pattern to print. The arm extends up to the front of the machine and has a handle on the end that the operator must push downwards and pull to get the printing unit to move forward.

TOOLS DRAWER

The table also includes one tools drawer located on the front of the machine where to keep tools and accessories used for printing or for the maintenance of the machine.